

SPARTAN HYDRANT

FEATURES AND BENEFITS

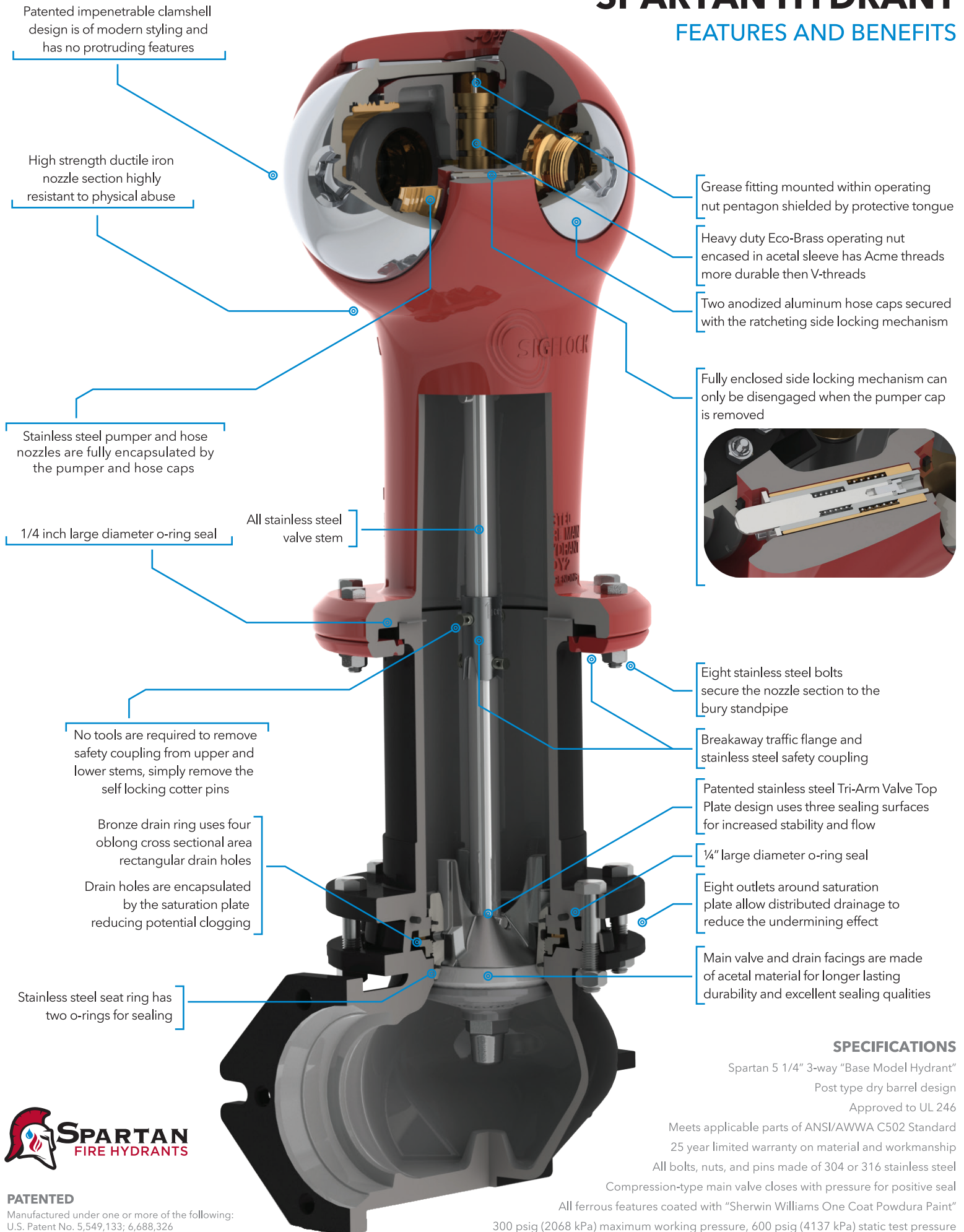

SPECIFICATIONS

Spartan 5 1/4" 3-way "Base Model Hydrant"

Post type dry barrel design

Approved to UL 246

Meets applicable parts of ANSI/AWWA C502 Standard

25 year limited warranty on material and workmanship

All bolts, nuts, and pins made of 304 or 316 stainless steel

Compression-type main valve closes with pressure for positive seal

All ferrous features coated with "Sherwin Williams One Coat Powdura Paint"

300 psig (2068 kPa) maximum working pressure, 600 psig (4137 kPa) static test pressure



PATENTED

Manufactured under one or more of the following:
U.S. Patent No. 5,549,133; 6,688,326

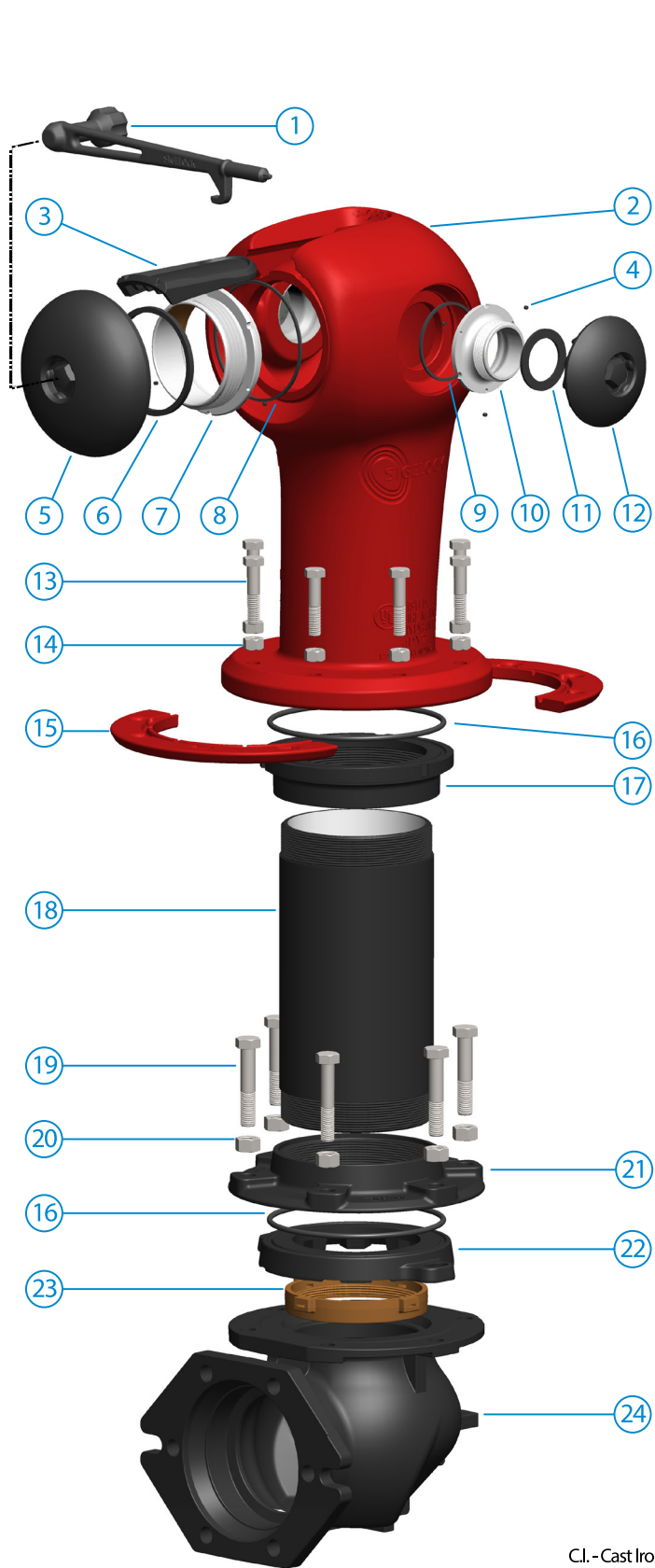

Item No.	QTY	Part Name / Description	Material
1	1	All-In-One Wrench	Stn. Stl.
2	1	Nozzle Housing	D.I.
3	1	Tamper Resistant Tongue	Al Alloy
4	9	Nozzle Set Screw	Stn. Stl.
5	1	Pumper Nozzle Screw Cap	Al Alloy
6	1	Pumper Screw Cap O-ring	EPDM
7	1	Pumper Nozzle	Stn. Stl.
8	1	Pumper Nozzle O-Ring	EPDM
9	2	Hose Nozzle O-Ring	EPDM
10	2	Hose Nozzle	Stn. Stl.
11	2	Hose Nozzle Cap O-ring	EPDM
12	2	Aluminum Hose Nozzle Cap	Al Alloy
13	8	Safety Flange Bolt	Stn. Stl.
14	8	Safety Flange Nut	Stn. Stl.
15	2	Safety Flange	C.I.
16	2	Standpipe O-Ring	EPDM
17	1	Standpipe Upper Flange	D.I.
18	1	Standpipe	D.I.
19	6	Inlet Flange Bolt	Da. Co. Stl.
20	6	Inlet Flange Nut	Da. Co. Stl.
21	1	Standpipe Lower Flange	D.I.
22	1	Saturation Ring	C.I.
23	1	Drain Ring	Eco Brass
24	1	Inlet Elbow	D.I.
25	1	Grease Fitting	Stn. Stl.
26	1	Grease Fitting O-Ring	EPDM
27	1	Operating Nut	Eco Brass
28	2	Operating Nut O-ring	Buna-N
29	1	Operating Nut Sleeve	POM
30	2	Low-Friction Thrust Washer 1	Stn. Stl.
31	1	Low-Friction Thrust Washer 2	POM
32	1	Operating Nut Bearing Washer	POM
33	1	Operating Nut Retain-Ring	Zn.Di.Stl.
34	1	Upper Operating Stem	Stn. Stl.
35	2	Self Locking Cotter Pin	Stn. Stl.
36	1	Safety Coupling	Stn. Stl.
37	2	Grooved Pin	Stn. Stl.
38	1	Lower Operating Stem	Stn. Stl.
39	1	Valve Seat Ring	Stn. Stl.
40	2	Valve Seat Ring O-ring	EPDM
41	3	Drain Valve Facing	POM
42	3	Drain Valve Screw	Stn. Stl.
43	1	Tri-Arm Valve Top Plate	Stn. Stl.
44	1	Main Seat Valve O-ring	EPDM
45	1	Main Seat Valve	POM
46	1	Lower Valve Plate	Stn. Stl.
47	1	Bottom Plate Nut O-Ring	EPDM
48	1	Bottom Plate Nut	Stn. Stl.

C.I. - Cast Iron
 D.I. - Ductile Iron
 Stn. Stl. - Stainless Steel
 Zn. Pl. Stl. - Zinc Plated Steel
 Bl. Ox. Stl. - Black Oxide Steel
 Zn.Di.Stl. - Zinc Dichromate Steel
 Da. Co. Stl. - Dacromet Coated Steel

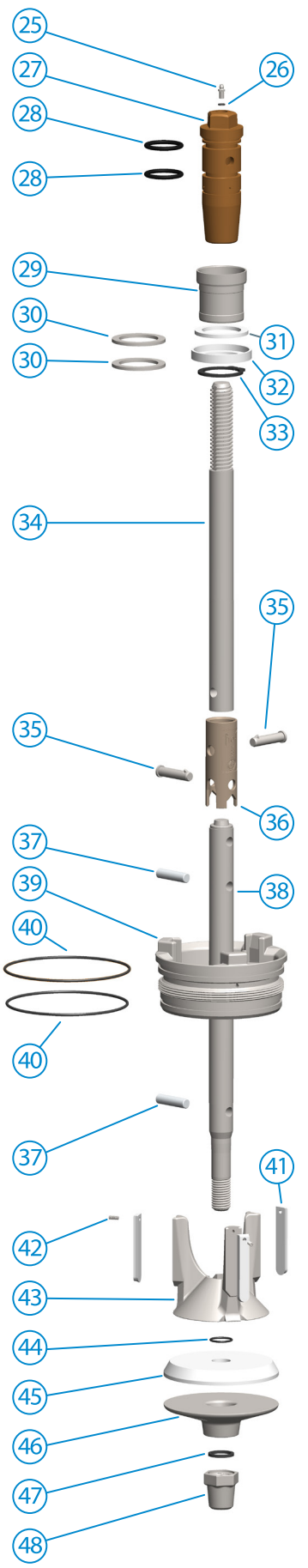

MANUFACTURED IN FRANKLIN, PA
HUB ZONE CERTIFIED

All products must be installed and maintained in accordance with applicable instructions and/or standards.